

574.507 DCGM 42 T42 BL

BRUSHLESS DC MOTOR WITH WORM GEAR



Ø 42 mm



24 V/DC



70 min⁻¹



18 Nm



-



eingebaut
built-in

CONNECTOR AT CONNECTION SIDE

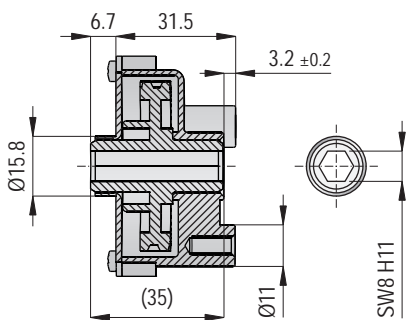
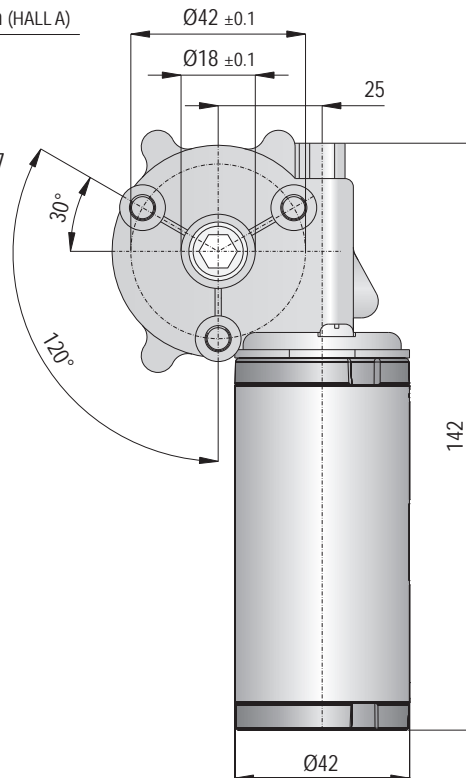
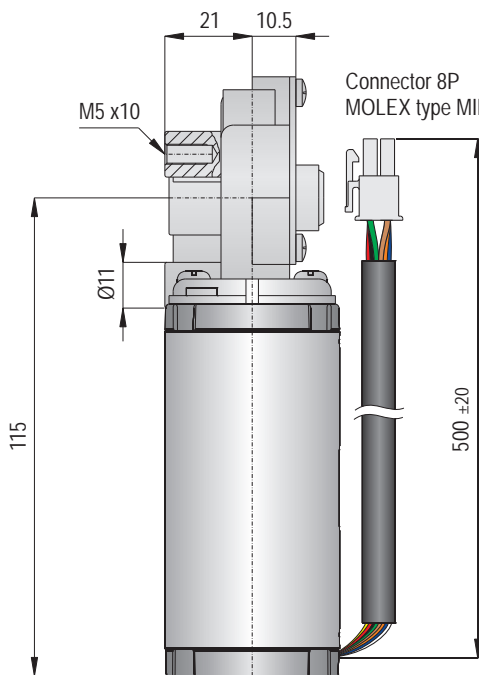
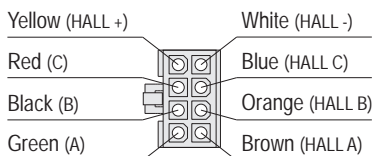

HINWEIS / Remark

Keine axialen oder radialen Belastungen der Hohlwelle zulässig! Die Abtriebswelle muss anwendungsseitig gegengelagert werden!

No axial or radial loads on the hollow shaft allowed! Shaft must be supported by ball-bearing or similar in the application!

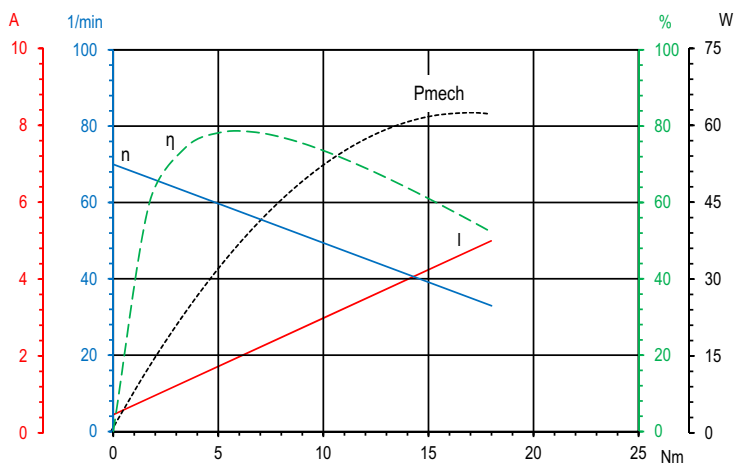

Diese Angaben sind Mittelwerte gemessen im kalten Zustand des Motors. Abweichungen von ±10% sind möglich. Technische Änderungen vorbehalten.
These data are measured average values at cold engine. Deviations from ±10% are possible. Subject to change without notice.

Technische Daten / Technical data

Nennspannung / Nominal voltage	24 V/DC
Leerlaufdrehzahl / No-load speed	70 min⁻¹
Nenn Drehmoment / Nom. torque	5 Nm
Maximalmoment / Max. torque	18 Nm
Hall-Sensor / Hall sensor	5 - 24 V/DC
Zahnradwerkstoff / Gear material	Kunststoff / Plastic
Übersetzung / Gear ratio	62:1
Schutzart / Protection class	IP 30
Gewicht / Weight	0,8 kg

BLDC 2022/2023

Allgemeines

Alle Angaben zu DC-Motoren sind Mittelwerte gemessen im kalten Zustand. Abweichungen von $\pm 10\%$ sind möglich. Technische Änderungen vorbehalten.

Aktuelle Informationen finden Sie auf unserer Internetseite unter www.seefrid.com.

General

All data to DC motors are measured average values at cold engine. Deviations from $\pm 10\%$ are possible. Subject to change without notice.

Current information you will find on our website www.seefrid.com.

Symbole / Symbols



Nennspannung [V]
Nominal voltage [V]



Leerlaufdrehzahl [min^{-1}]
No-load speed [rpm]



Maximalmoment [Nm]
Maximum torque [Nm]



\varnothing Motortopf [mm]
Motor diameter [mm]



Motorbefestigung [mm]
Mounting of motor [mm]



Hall-Sensor
Hall sensor



EMV Entstörung
EMC filter

Toleranzfelder nach DIN ISO 286 / Tolerances according to DIN ISO 286

• Innendurchmesser (Bohrungen / Holes)	9,6 h10	: 0 / -0,058 mm	
1,1 H13	: +0,140 / 0 mm	10 h8	: 0 / -0,022 mm
3 N9	: -0,004 / -0,029 mm	10 f6	: -0,013 / -0,022 mm
3 P9	: -0,006 / -0,031 mm	10 f7	: -0,013 / -0,028 mm
4 H7	: +0,012 / 0 mm	10 f8	: -0,013 / -0,035 mm
		10 k7	: +0,016 / +0,001 mm
• Außendurchmesser (Wellen / Shafts)	12 h7	: 0 / -0,018 mm	
3 h9	: 0 / -0,025 mm	12 g5	: -0,006 / -0,014 mm
3,7 h11	: 0 / -0,075 mm	12 f7	: -0,016 / -0,034 mm
6 h7	: 0 / -0,012 mm	12,5 f7	: -0,016 / -0,034 mm

Umrechnungen (für die Praxis gerundete Werte) / Conversion (rounded values)

• Kräfte / Forces

$$1 \text{ N} = 0,1 \text{ kg} = 100 \text{ g} \quad 1 \text{ kg} = 10 \text{ N} = 10.000 \text{ mN}$$

• Drehmomente / Torques

$$1 \text{ Nm} = 10.000 \text{ g/cm} = 10 \text{ kg/cm} \quad 1 \text{ kg/cm} = 0,1 \text{ Nm} = 10 \text{ Ncm}$$

$$1 \text{ Ncm} = 100 \text{ g/cm} = 0,1 \text{ kg/cm} \quad 1 \text{ g/cm} = 1 \cdot 10^{-4} \text{ Nm} = 1 \cdot 10^{-2} \text{ Ncm}$$

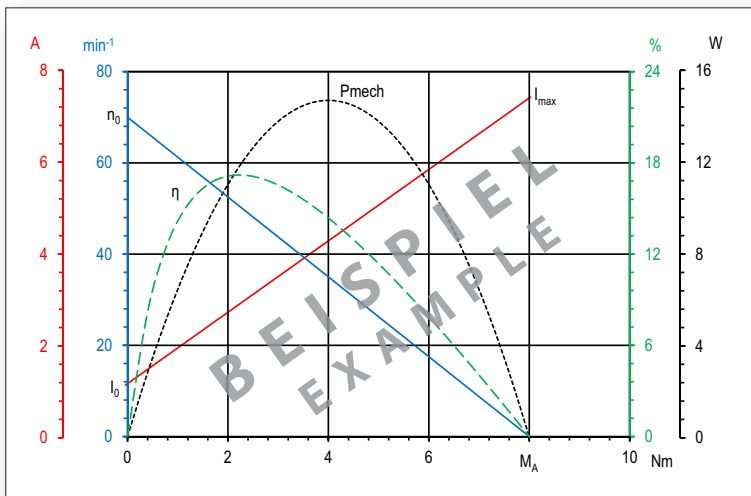
Kennlinie / Diagram

Legende / Description

- n_0 = Leerlaufdrehzahl / No-load speed [min⁻¹]
- η = Wirkungsgrad / Efficiency [%]
- P_{mech} = mech. Leistung / Mech. power [W]
- I_0 = Leerlaufstrom / No load current [A]
- I_{max} = Maximalstrom / Max. current [A]
- M = Drehmoment / Torque [Nm]
- M_A = Anlaufmoment / Starting torque [Nm]

IP-Schutzarten nach DIN EN 60529 / Protection classes according to DIN EN 60529

- **1. Ziffer (Fremdkörperchutz)**
First digit (Solid objects protection)
 - 0 - ohne Schutz
no protection
 - 1 - Schutz gegen Fremdkörper > 50 mm
Protected against solid objects > 50 mm
 - 2 - Schutz gegen Fremdkörper > 12 mm
Protected against solid objects > 12 mm
 - 3 - Schutz gegen Fremdkörper > 2,5 mm
Protected against solid objects > 2,5 mm
 - 4 - Schutz gegen Fremdkörper > 1 mm
Protected against solid objects > 1 mm
 - 5 - Schutz gegen schädliche Staubablagerungen
Limited protected against dust ingress
 - 6 - staubdicht
Totally protected against dust ingress
- **2. Ziffer (Wasserschutz)**
Second digit (Water protection)
 - 0 - ohne Schutz
no protection
 - 1 - Schutz gegen senkrecht fallendes Tropfwasser
Protected against vertically falling drops of water
 - 2 - Schutz gegen Tropfwasser bis 15° Neigung
Protected against vertically falling drops of water in max. angle of 15°
 - 3 - Schutz gegen Sprühwasser bis 60° Neigung
Protected against vertically falling drops of water in max. angle of 60°
 - 4 - Schutz gegen Spritzwasser
Protected against splash water from any direction
 - 5 - Schutz gegen Strahlwasser
Protected against low pressure water jets form any direction
 - 6 - Schutz gegen starkes Strahlwasser
Protected against high pressure water jets form any direction
 - 7 - Schutz gegen zeitweiliges Eintauchen
Protected against short periods of immersion in water
 - 8 - Schutz gegen dauerhaftes Untertauchen
Protected against log, durable periods of immersion in water