

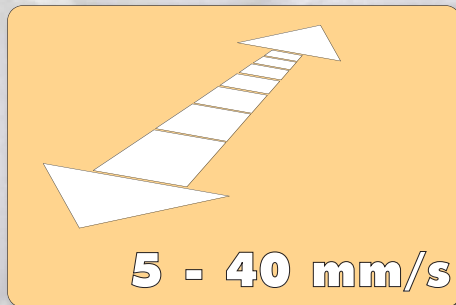

offene Spindel
unprotected acme-screw

DCSA 36

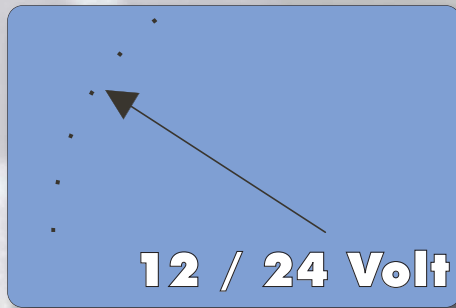

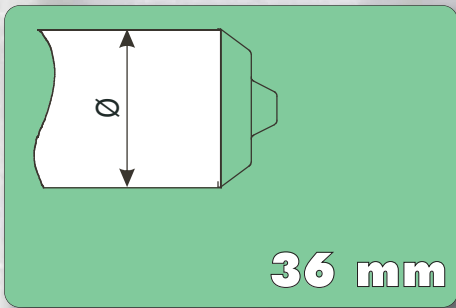
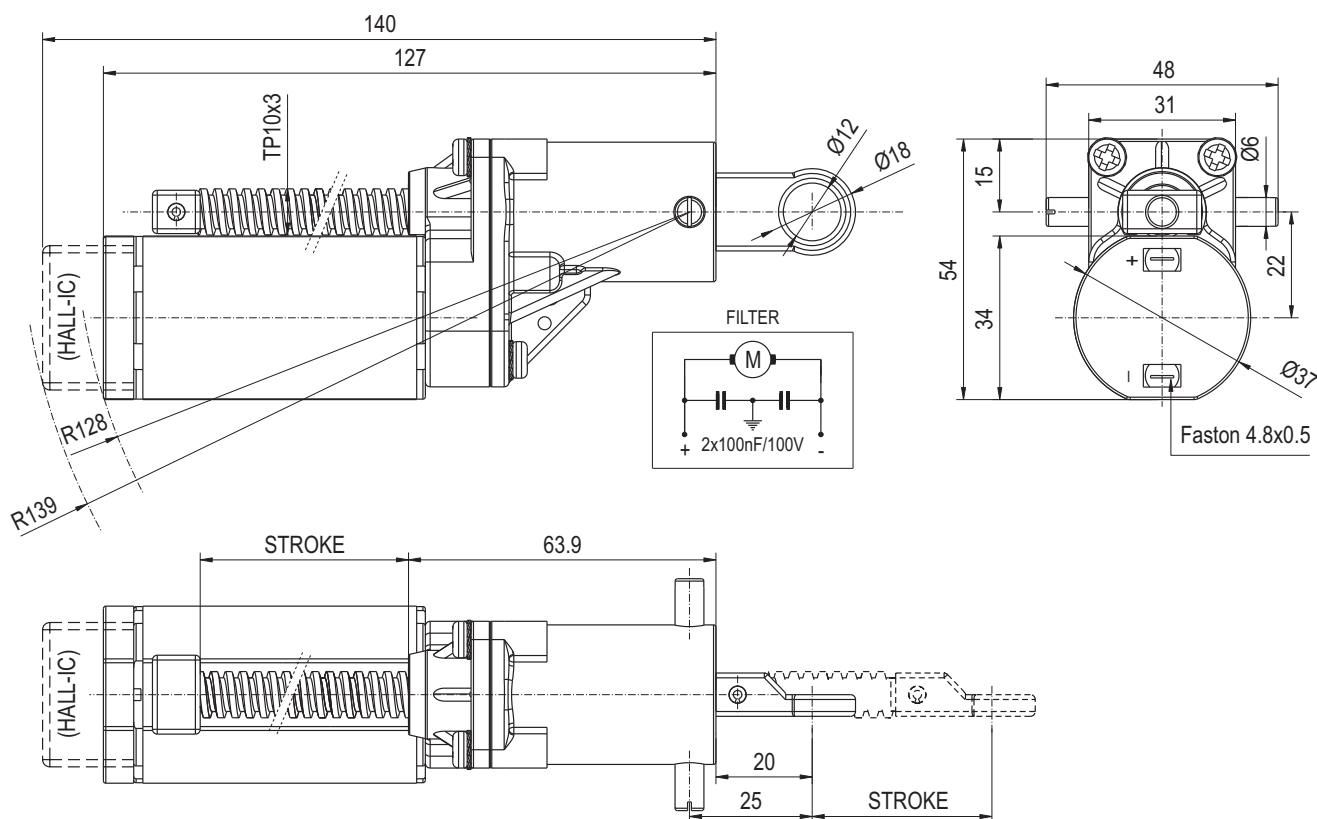

Anschluss mit Hall-IC / Connection diagram with hall-sensor

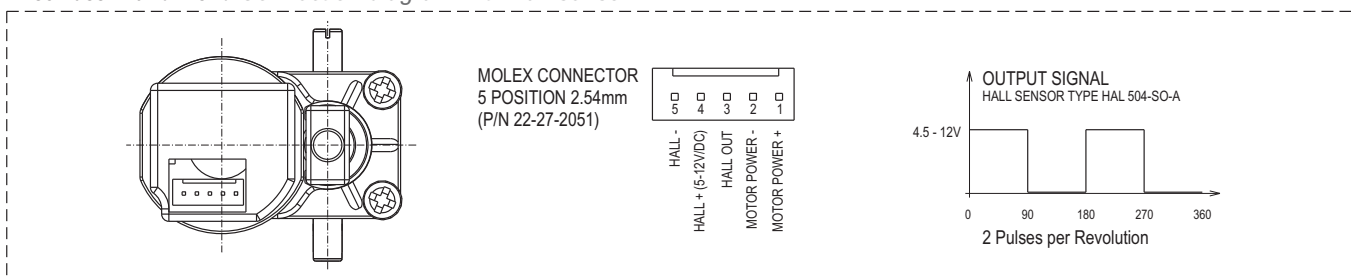

Allgemeine Toleranzen: Bohrungen H13, Wellen h13, Winkel ±30°, Gewinde: Schrauben Sh6 / Muttern SH6.
 General tolerances: Drillings H13, Shafts h13, Angles ±30°, Threads: Screws Sh6 / Nuts SH6.

Technische Daten / Technical data

Nennspannung / Nominal voltage : 24(12) V/DC

Bestell-Nr. Order-No.	Leerlaufgeschw. No-load speed	i Gear ratio	Hubhöhen Strokes	Einschaltdauer Duty cycle	Nennstrom Nom. current	nom. Hubkraft nom. load	max. Hubkraft max. load
600.015 - 600.021	5 mm/s	50:1	50 mm	70 %	1,0 A	100 kg	170 kg
600.009 - 600.014	10(5) mm/s	50:1	100 mm	30(50) %	3,2 A	120 kg	210(160) kg
600.001 - 600.008	18(9) mm/s	12:1	120 mm	50(80) %	1,5 A	40 kg	70(30) kg
600.022 - 600.028	40(20) mm/s	12:1	200 mm	30(50) %	3,6 A	40 kg	80(60) kg
			250 mm				
			300 mm				

Nennspannung / Nominal voltage : 24(12) V/DC - mit Hall-IC / with hall sensor

Bestell-Nr. Order-No.	Leerlaufgeschw. No-load speed	i Gear ratio	Hubhöhen Strokes	Einschaltdauer Duty cycle	Imp./s Pulse/s	Nennstrom Nom. current	nom. Hubkraft nom. load	max. Hubkraft max. load
600.115 - 600.121	5 mm/s	50:1	50 mm	70 %	195	1,0 A	100 kg	170 kg
600.109 - 600.114	10(5) mm/s	50:1	100 mm	30(50) %	380	3,2 A	120 kg	210(160) kg
600.101 - 600.108	18(9) mm/s	12:1	120 mm	50(80) %	195	1,5 A	40 kg	70(30) kg
600.122 - 600.128	40(20) mm/s	12:1	200 mm	30(50) %	380	3,6 A	40 kg	80(60) kg
			250 mm					
			300 mm					

Diese Angaben sind Mittelwerte gemessen im kalten Zustand des Motors. Abweichungen von ±10% sind möglich. Technische Änderungen vorbehalten.
 These data are measured average values at cold engine. Deviations from ±10% are possible. Subject to change without notice.